

DTZ14S-C

Specifications

Model NO .	DTZ14S-C	
Upgrade From	YTZ14S	
Nominal Voltage	12V	
Rated Capacity (10 hours rate)	11.2 Ah	
Dimensions	Length	150 mm (5.91 inches)
	Width	86 mm (3.39 inches)
	Height	111 mm (4.37 inches)
	Total Height	111 mm (4.37 inches)
Approx. Weight	3.74 kg (8.25 Lbs)	
Charge Current (A)	1.12 A (14.4V constant voltage charge)	

Characteristics

Capacity 25°C(77°F)	10 hours rate (1.12 A to 10.5V)	11.2 Ah
	5 hours rate (2.3 A to 10.2V)	9.5 Ah
	1C (11.2A to 9.6V)	5.0 Ah
	3C (33.6 A to 9.6V)	4.0 Ah
Cranking Amperes(by Midtronic Tester)	400 A	
Cold Cranking Amperes(-18°C SAE Standard)	200 A	
Cold Cranking Amperes(-18°C EN Standard)	200 A	
Internal Resistance (at 1KHz)	Approx. 10mΩ	
Operating Temperature Range	Charge	0°C (32°F) to 40°C (104°F)
	Discharge	-30°C (-22°F) to 50°C (122°F)
	Storage	-15°C (5°F) to 40°C (104°F)
Life Expectancy (Cycle Use)	60% depth of discharge 250 cycles	
	30% depth of discharge 400 cycles	
Charge Retention (self-discharge life) at 20°C (68°F)	1 month	92%
	3 month	90%
	6 month	80%
Warranty	1 year	
Case Material	ABS	



Dimensions

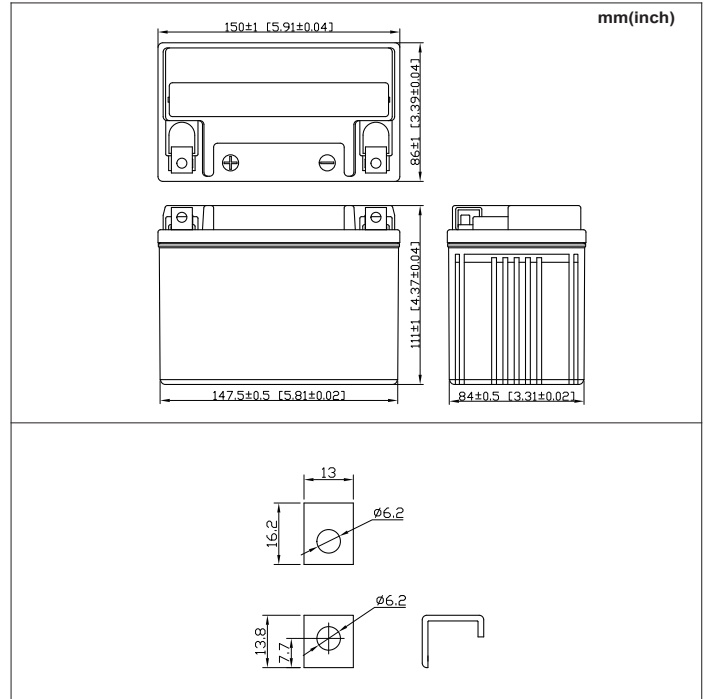

(V)
FOR 12V
BATTERY

