

MODEL: PR100-12(GEL)

NO.: 302020001-00029

POWER

Plane Chart:

Unit:(mm) Terminal type:(T3)

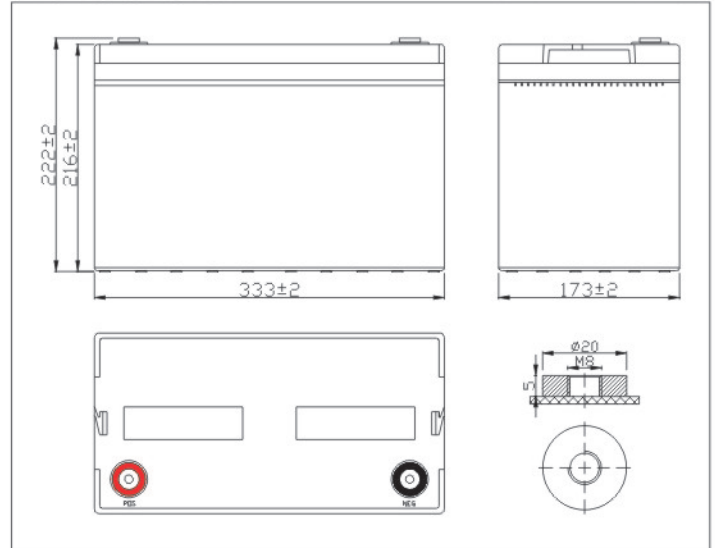

ISO 9001
ISO 14001
OHSAS18001



Parameter Chart:

Volts		12V	
Capacity(25°C)	10 hours rate (10A)	100Ah	
Discharge Current Testing (25°C)	1 hours rate (55A)	57Ah	
	3 hours rate (25A)	77Ah	
Internal Resistance	Full Charged Battery 25°C	4.2mΩ	
Capacity Affected By Temperature	40°C	104%	
	25°C	100%	
	0°C	83%	
	-15°C	65%	
Residual Capacity (25°C)	Capacity After 3 Months Storage	91%	
	Capacity After 6 Months Storage	82%	
	Capacity After 12 Months Storage	65%	
Charge (Constant Voltage)	Cycle (25°C)	Initial Charging Current Less Than 30A Voltage 14.5~14.9V	
	Float (25°C)	Charge Voltage 13.6~13.8V	
Weight (Approx)		30.5Kg	

Residual Capacity

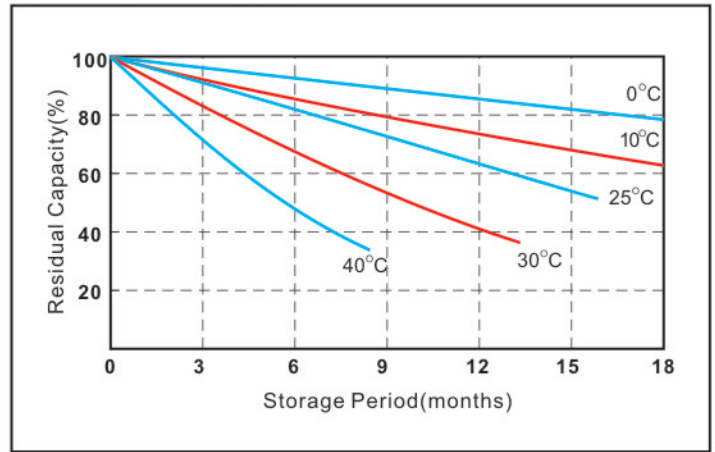

Discharge Current 25°C

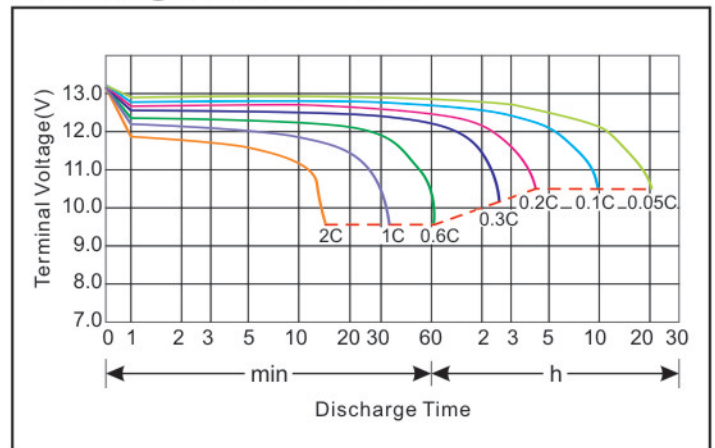

★The above are average and data obtained from the first 3 charge/discharge cycles. These are not minimum values.

Constant voltage charging characteristics

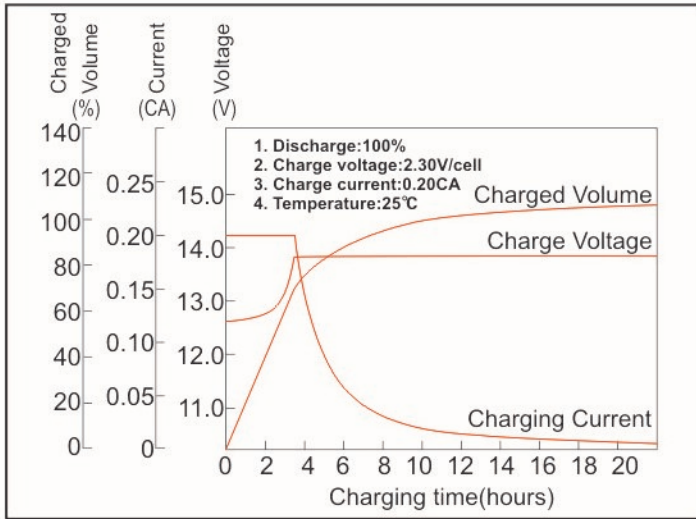

Cycle service life in relation to the depth of discharge

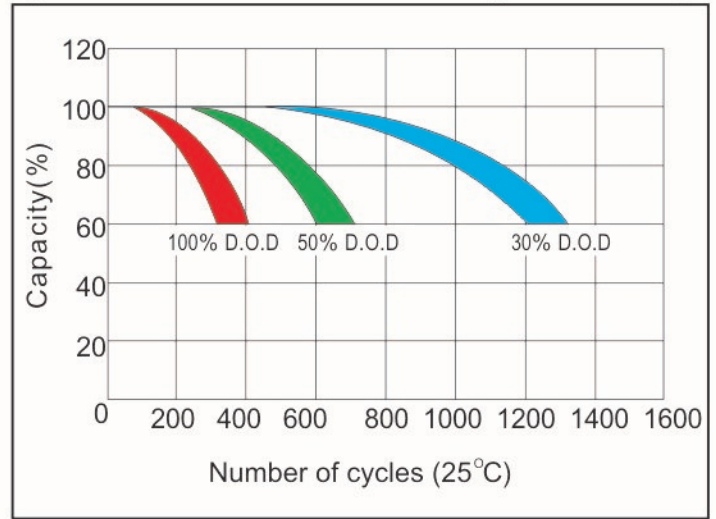

Constant Current Discharge Characteristics (A, 25°C)

F.V/Time	10min	15min	30min	60min	2h	3h	5h	8h	10h	20h
9.60V	217.8	173.3	106.9	64.4	36.1	26.1	18.3	12.1	10.1	5.4
10.2V	206.9	166.3	103.0	61.8	35.6	25.7	18.0	12.0	10.0	5.3
10.5V	201.0	162.4	100.0	60.5	35.3	25.5	17.8	12.0	10.0	5.3
10.8V	194.0	158.4	97.8	58.7	34.9	25.2	17.6	11.9	10.0	5.2

Constant Power Discharge Characteristics (Watt, 25°C)

F.V/Time	10min	15min	30min	60min	2h	3h	5h	8h	10h	20h
9.60V	2352.2	1902.8	1199.9	733.6	418.8	306.9	216.8	144.5	121.8	64.3
10.2V	2234.4	1826.6	1155.3	703.9	412.8	302.9	212.9	143.9	120.8	63.6
10.5V	2170.1	1782.0	1145.4	699.9	408.9	300.0	209.9	143.6	119.8	63.4
10.8V	2095.8	1739.4	1097.9	669.2	404.9	297.0	207.9	142.6	118.2	63.0

Capacity Factors With Different Temperature

Battery Type		-20°C	-10°C	0°C	5°C	10°C	20°C	25°C	30°C	40°C	45°C
GEL Battery	12V	50%	70%	83%	85%	90%	98%	100%	102%	104%	105%

★The above are average and data obtained from the first 3 charge/discharge cycles. These are not minimum values.